

Details of Pole Head  
S=1/10

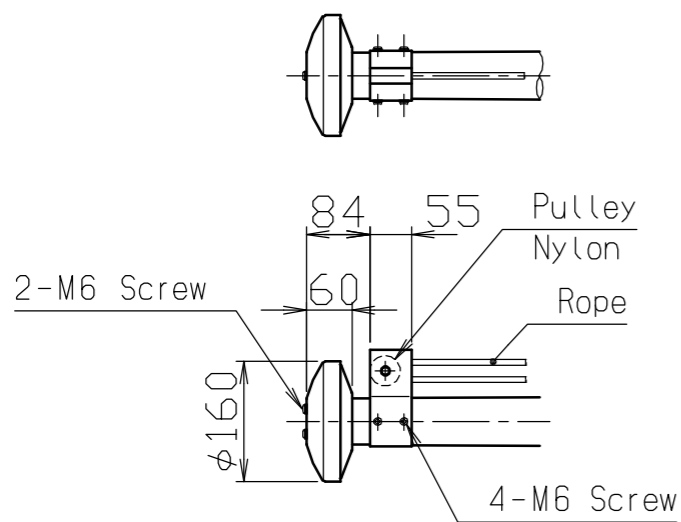

Details of cleat  
S=1/10

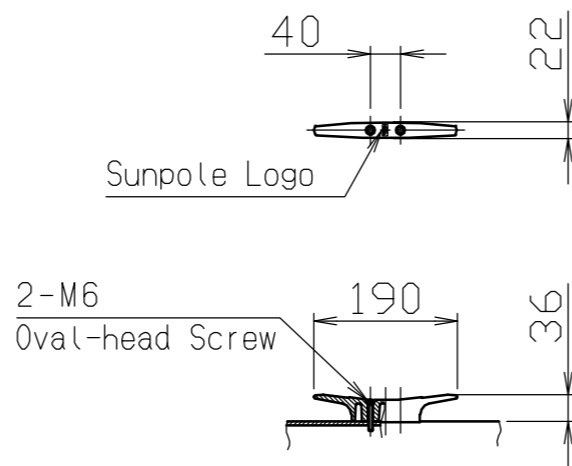

Details of Base  
S=1/10

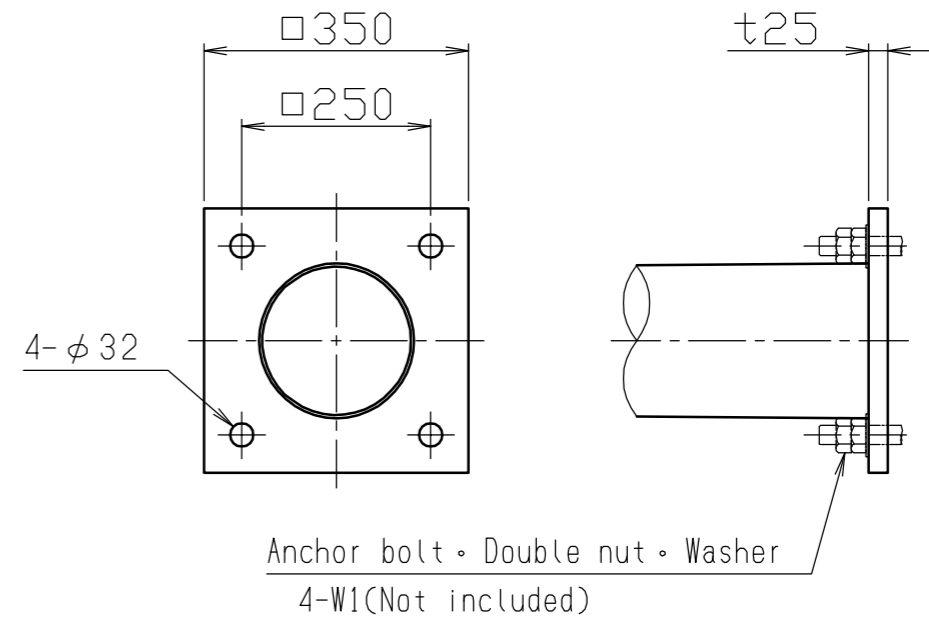

※ For safety, please refrain from using the flag when the wind speed is more than 15 meters/second.

No.	Product Name	Qty	Material	Remarks	承認 APPR.	検図 C. BY	製図 D. BY	年月日 DATE	品名 SUBJ.	図番 DRAWING No.	DWG A3 SIZE
5	Base	1	Steel plate SS400	□350×t25.0 Hot dip galvanized					SFP-9BS		2001
4	Cleat	1	Aluminum alloy die casting ADC6	Clear baking coating finish after buffing							
3	Pulley System	1	Aluminum alloy A6063S-T5	Baking coating finish							
2	Pole Head	1	Aluminum alloy/Polypropylene A1050P/PP	Alumite treatment							
1	Pole	1	Steel pipe SS400	φ60-φ205 Hot dip galvanized (astm A123)							
					European Flagpole Co., Ltd. Sunpole Japan group			尺度 SCALE			
								1 / 30			